

TECHNICAL GUIDE

**Single Package
Air Conditioner with Electric Heat
14.0 SEER (13.4 SEER2) - R-410A
Three-Phase - 208/230 V
3 nominal ton to 5 nominal ton
Models: PCE4*36 to 60**



Assembled at a facility with
an ISO 9001:2015-certified
Quality Management
System

Due to continuous product improvement, specifications are subject to change without notice.

Visit us on the web at

www.simplygettingthejobdone.com

Additional rating information can be found at

www.ahridirectory.org

WARRANTY SUMMARY

Standard 1-year limited parts warranty.

Standard 5-year limited compressor warranty.

See the limited warranty certificate in the *User's Information Manual* for details.

Description

These packaged cooling and heating air conditioners are designed for outdoor installation. Only utility and duct connections are required at the point of installation.

Features

- **Operating efficiency** - All PCE4 air conditioner models are rated at 14.0 SEER (13.4 SEER2) for cooling operation.
- **On-site flexibility** - All model sizes use a compact design cabinet in one of two footprints. This provides installer flexibility for placing the correct capacity unit on curbs or pads with the smallest footprint after the internal load has been determined. Field convertible duct connections from side shot to down shot allow the installer to have greater flexibility with less inventory.
- **Lower installation cost** - Installation time and costs are reduced by easy power and control wiring connections. The small base dimension means less space is required on the ground or roof. All units are completely wired, charged with R-410A, and tested before shipment. Test stations using a state-of-the-art computerized process system are used to ensure product quality. Refrigerant charge and component part numbers are verified using computers during assembly. Vital run test statistics such as system pressure, motor currents, air velocity and temperature, unit vibration, and gas system safeties are monitored and recorded by the system to ensure unit performance. Equal size side supply and return duct connections allow easy connection of ducts to match low crawl spaces without transition pieces.
- **Utility connections made easy** - Electric utility access provided through the bottom or the side of the unit. Utility connections can be made quickly and with a minimum amount of field labor. A field-supplied and field-installed electrical disconnect switch must be installed.
- **Convertible airflow design** - The bottom duct openings are covered when they leave the factory, ready to be used for a side supply and side return application. If a bottom supply and bottom return application is required, remove the two panels from the bottom of the unit and place them in the side supply and side return duct openings. No panel cutting is required and no accessory panel is necessary. Convertible airflow design allows maximum field flexibility and minimum inventory.
- **Condensate pan** - A corrosion-resistant, long-lasting, water-tight pan is positioned below the indoor coil to collect and drain all condensate, preventing build-up of stagnant condensate. The condensate pan conforms to ASHRAE 62-19 standards (Ventilation for Acceptable Indoor Air Quality).
- **Condensate drain** - The 3/4 in. NPT female connection is rigidly mounted to ensure correct fit and leak tight seal.
- **Durable finish** - The cabinet is made of G90 galvanized steel with a powder paint coating for appearance and protection. The pre-treated galvanized steel provides a better paint-to-steel bond, which resists corrosion and rust creep. Powder paint finish ensures less fading when exposed to sunlight, and provides superior corrosion resistance. The paint is 1,000 h salt spray tested.

- **Full perimeter base rails** - The easily removable base rails provide a solid foundation for the entire unit and protect the unit during shipment. The rails provide forklift access from all sides, and rigging holes are also provided so an overhead crane can be used to place the units on a roof. On applications where the unit is placed on a pad, the base keeps the unit off the pad to deter corrosion. On applications where height is limited, the base rails may be removed by removing two screws in each corner.
- **Attractive appearance** - A single-piece top cover containing a top-discharge outdoor fan arrangement requires less square footage on installation and provides a wider variety of installations. The one-piece design adds greater water integrity. Rounded corners with water drip edges add to the attractive appearance.
- **Top discharge** - The top-discharge outdoor fan does not disrupt neighboring areas or dry out vegetation surrounding the unit. The warm air from the top mounted fan is blown up and away from the structure and any landscaping.
- **Outdoor coil grille** - All models use a stamped slotted design that provides superior impact protection against small objects during transit and after installation.
- **Low operating sound level** - The upward airflow carries the normal operating noise up and away from the living area. The rigid top panel effectively isolates noise. Isolator mounted compressor and the rippled fins of the outdoor coil muffle the normal fan motor and compressor operating sounds. The unique formed base pan also aids in sound attenuation with its structural design.
- **Fan system** - All models operate over a wide range of design conditions with a standard ECM indoor blower motor. These units easily match all types of applications and provide greater on-site flexibility to match comfort requirements. The cooling speed is factory set and can be field-adjusted to a second speed. The heating speed is factory set to maintain mid point rise at the units' heating input, but can be field adjusted. This allows for maximum comfort conditions.
- **Simple control circuit** - Field thermostat wiring connects to color coded leads using twist-on wire connections. Cooling controls use contactor and relays for simple application and troubleshooting. MATE-N-LOK plug connectors are used. The electrical control box is not located in the compressor compartment. The controls are mounted to allow the separate access panel to be removed for troubleshooting and maintenance without affecting the normal system operating pressures. All wiring internal to the unit is color-coded and numbered.
- **Protected compressor** - The compressor is internally protected against high pressure and temperature. This is accomplished by the simultaneous operation of a high pressure relief valve and a temperature sensor, which protects the compressor if unwanted operating conditions occur.
- **High-pressure switch** - A high-pressure switch is standard in all units. It is an automatic reset switch. When discharge pressure reaches 650 psi, the compressor de-energizes until pressure reaches 450 psi.
- **Exclusive coil design** - The grooved copper tubes and enhanced aluminum fin construction of the outdoor coils improve heat transfer for maximum efficiency and durability. Indoor tube and fin coils have all aluminum construction for reliability and efficient heat transfer.
- **Electric heat** - All electric heat models use 6HK electric heat, which is available in 208/230-3-60 from 10 kW to 25 kW. Most kits are stageable above 10 kW.
- **Low maintenance** - Long-life, permanently lubricated outdoor fan motor bearings and indoor blower motor bearings do not need annual maintenance, adding greater reliability to the unit. Slide-out blower assembly and indoor coil assembly can be easily removed for cleaning.
- **Easy service access** - Individual access panels provide access to all major components, for example, compressors, indoor coils, blowers, controls and electric heat kits, and filters, making servicing easy. Removing these panels allows easy removal of components such as the blower assembly for maintenance and troubleshooting.
- **Replacement parts** - The installer requires no special training to replace any of the components of these units. The number of new components has been reduced to minimize the inventory of unique parts.
- **Filter/frame kit** - All three-phase PCE units include a filter/frame kit, which is shipped inside the unit from production. Field installation is required.
- **Filters** - All three-phase PCE units include an applicable number of 1-in. washable filters, which are shipped inside the unit from production. Field installation is required. Two filters are required for A base units. Three filters are required for B base units.

Nomenclature

Model family	PCE	PHE = packaged heat pump with electric heat
		PCG = packaged AC with gas heat
		PHG = packaged heat pump with gas heat
		PCE = packaged AC with electric heat
Nominal cooling efficiency	4	4 = standard efficiency
		6 = high efficiency
Cabinet size	A	A = small, 35.75 in. x 51.25 in.
		B = large, 45.75 in. x 51.25 in.
Nominal air conditioning cooling capacity Btu/h x 1000	36	24 = 24,000 Btu/h
		30 = 30,000 Btu/h
		36 = 36,000 Btu/h
		42 = 42,000 Btu/h
		48 = 48,000 Btu/h
		60 = 60,000 Btu/h
Gas heating input Btu/h x 1000		050 = 50,000 Btu/h input
		065 = 65,000 Btu/h input
		075 = 75,000 Btu/h input
		100 = 100,000 Btu/h input
		125 = 125,000 Btu/h input
		blank = electric heat
Voltage-phase-frequency	3	2 = 208/230-1-60
		3 = 208/230-3-60
		4 = 460-3-60
		X = Low NOx
NOx approval		blank = not Low NOx
Generation level	4	1 = first generation
		2 = second generation
		3 = third generation
		4 = fourth generation
Revision level	A	A = original release
		B = second release

Nomenclature example: PCE4A3634A is a packaged AC with electric heat, standard efficiency, small cabinet, 3 ton, 208/230 V, three-phase model, fourth generation, original release.

Component location

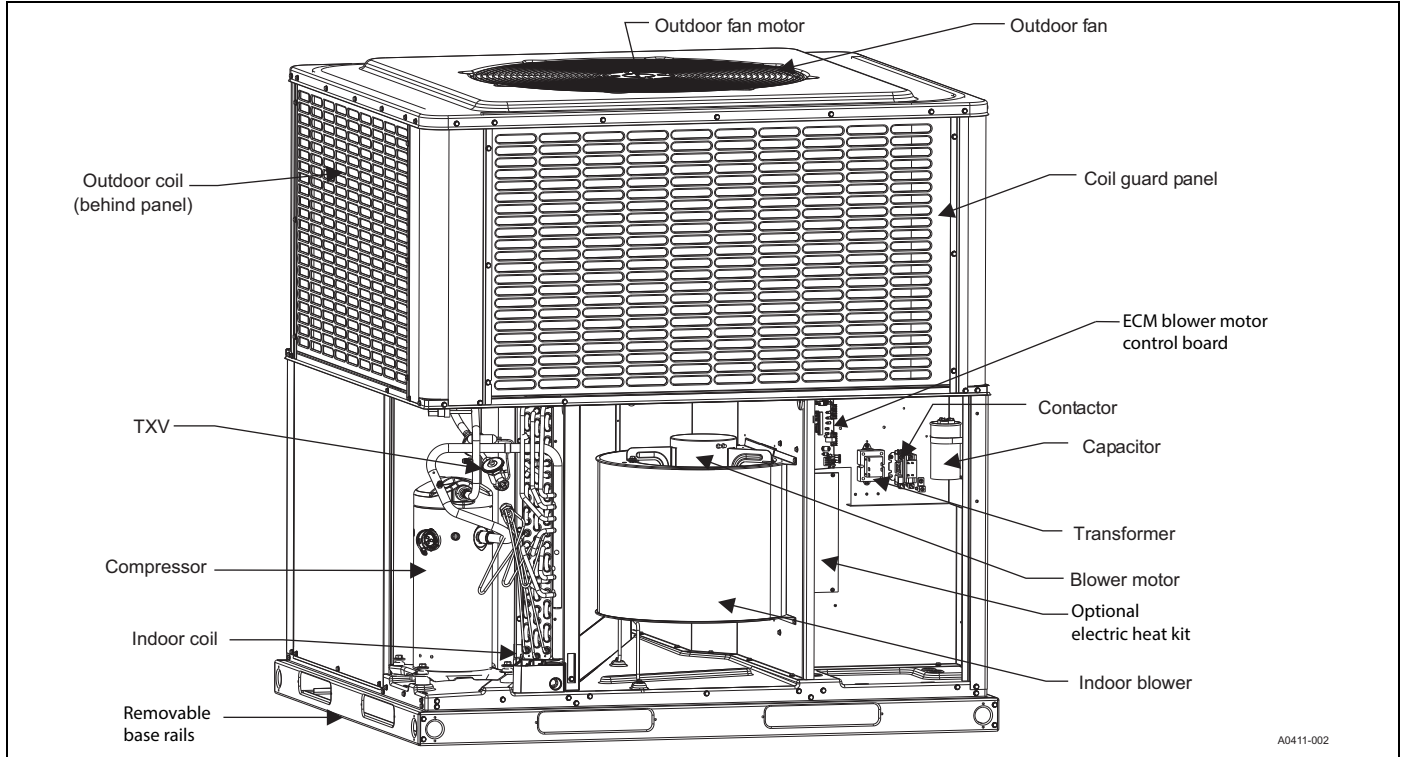

Unit limitations

Model	Voltage-phase-frequency	Unit limitations		
		Applied voltage (V)		Outdoor DB temperature (°F)
		Minimum	Maximum	Maximum
PCE4A36	208/230-3-60	187	252	125
PCE4B48	208/230-3-60	187	252	125
PCE4B60	208/230-3-60	187	252	125

Application limitations

Packaged equipment series	Air temperature at outdoor coil (°F)		Air temperature at indoor coil (°F)	
	Minimum	Maximum	Minimum	Maximum
	DB Cool	DB Cool	WB Cool	WB Cool
PCE4	55	125	57	72

Accessories

- **Anchor Bracket Kit (S1-1HK0601)** - This kit firmly anchors PCG, PCE, PHE, and PHG packaged units to a pad or support structure. When correctly installed, the kit is approved for ground-mounted or roof-mounted applications, wind load certified, and listed with the State of Florida. See <https://floridabuilding.org> for this listing.
- **Economizer for Downflow Applications (S1-2EE04710024, S1-2EE04710124)** - Modulating integrated economizer provides simultaneous operation between mechanical cooling and economizer operation. Independent blade design ensures sufficient control and less than 1% leak rate. Includes hood and mesh bird screen filter integrated into the hood, dry bulb sensor, and barometric relief damper. Separate field accessories of single/dual enthalpy kits are also available.
- **Economizer for Horizontal Applications (S1-2EE04710224, S1-2EE04710324)** - Modulating integrated economizer provides simultaneous operation between the mechanical cooling and economizer operation. Independent blade design ensures sufficient control and less than 1% leak rate. Includes hood and mesh bird screen filter integrated into hood and dry bulb sensor. Separate field accessories of single enthalpy and dual enthalpy are available.
- **Barometric Relief Hood (S1-1RD0501)** - Used in conjunction with a horizontal economizer, the barometric relief hood helps to equalize the building pressure caused by the fresh air introduced through the economizer fresh air hood.
- **Single/Dual Enthalpy Sensor (S1-HE-69630NS-2D)** - Sensor replaces supply air temperature dry bulb sensor standard in economizer kit. Provides improved economizer operation by sensing the dry bulb temperature of indoor supply air plus the enthalpy content of the outdoor air.
- **Duct/Unit Mount CO₂ Kit (S1-2AQ04700924)** - Sensor kit detects CO₂ levels automatically and overrides the economizer when CO₂ levels rise above the preset limits.
- **Wall Mount CO₂ Kit (S1-2AQ04701024)** - Sensor kit detects CO₂ levels automatically and overrides the economizer when CO₂ levels rise above the preset limits.
- **Supply Air Temperature Sensor Kit (S1-TE-63616E-2D)** - Outdoor supply air temperature sensor kit is used with economizers.
- **Filter/Frame Kit (Provided) (S1-1FF0602, S1-1FF0601)** - Kit contains the necessary hardware to field install return air filters into the base unit. The filter rack is suitable for 1-in. filters or 2-in. filters.
- **Filter (S1-02647812000)** - Washable 1-in. filter. Two filters are required for A base units. Three filters are required for B base units. Washable filters are included inside shipped units for field installation.
- **Motorized Fresh Air Damper (S1-2MD04705224, S1-2MD04705124)** - Designed for duct mounted side supply and return and unit mounted down supply and return applications. Damper capable of providing 0% through 50% of outdoor air (field supplied). Closes on power loss and includes hood and screen assembly.
- **Rectangle to Round (Horizontal) Adapter (S1-1AK0110, S1-1AK0111)** - Kit includes one supply and one return air rectangle to round duct adapter. Adapters are preformed and designed to fit over current horizontal duct openings on the base unit. Transition is from rectangle to 12 in. round for the 1AK0110 kit and from rectangle to 14 in. round for the 1AK0111 kit.
- **Rectangle to Round (Downflow) Adapter (S1-1AK0108, S1-1AK0109)** - Kit includes one supply and one return air rectangle to round duct adapter. Adapters are preformed and designed to fit into current downflow duct openings on the roof curb. Transition is from rectangle to 16 in. round for the 1AK0108 kit and from rectangle to 18 in. round for the 1AK0109 kit.
- **Roof Curbs (S1-1RC0503, S1-1RC0501)** - NRCA approved curbs provide correct fit to base unit for rooftop installations. Curbs are designed to be assembled through hinge pins in each corner. Kit also provides seal strip to ensure an air tight seal. These are 8-in. high roof curbs.
- **Roof Curbs (S1-1RC0504, S1-1RC0502)** - NRCA approved curbs provide correct fit to base unit for rooftop installations. Curbs are designed for assembly through hinge pins in each corner. Kit also provides seal strip to ensure an air tight seal. These are 14-in. high roof curbs.
- **Transition Curb Kits (S1-1TC01*)** - These adapter kits allow field use of existing installed roof curbs, matching the PCE4 footprint to Affinity roof curbs or Carrier, Trane, or Goodman roof curbs. Curb adapters are optional for current generation Carrier replacements, but are recommended for previous generation applications. Refer to the PCE4 *Price Pages* for more details.
- **Manual Outdoor Damper (S1-1FA0502, S1-1FA0501)** - Provides 0% through 50% outdoor air capability (field adjustable). Designed for duct mounted side supply and return applications and unit mounted down supply and return applications. Includes hood and screen assembly.
- **Loss of Charge Switch (S1-2LC00024)** - Kit provides loss of charge switch and wiring to provide safe shutdown of compressor.
- **Low Ambient Kit (S1-2LA04701024)** - Kit provides necessary hardware to convert unit to operate in cooling cycle down to 0°F. Standard unit operation is 55°F.
- **Base Rail Hole Cover Kit (S1-1HC0101)** - Kit provides necessary hardware to close off openings in base rails to block off openings and prevent animal entrance.
- **Single-Point Wiring Kits (S1-2SPWK031 through 038)** - This kit provides terminal block, fuse block, and wiring to allow units with electric heat to be connected to a single source of incoming power.
- **Thermostat** - Compatible thermostat controls are available through accessory sourcing. For optimum performance, these outdoor units are fully compatible with our residential Hx™ Touch Screen Thermostat available through Source 1. For more information, refer to the *Thermostats and controllers* at www.simplygettingthejobdone.com.
- **Wall Thermostat** - The units are designed to operate with standard 24 V electronic non power stealing and electromechanical thermostats. All units can operate with single-stage heat and single-stage cool thermostats - with or without the economizer.

* For additional kit numbers refer to the *Price Pages*.

Guide specifications

General

Units shall be assembled at a facility with an ISO 9001:2015-certified Quality Management System. These packaged cooling and heating air conditioners are designed for outdoor installation. Only utility and duct connections are required at the point of installation. Air conditioning units provide electric cooling and electric heating, with field installed electric heat kits from 2 kW to 25 kW for heating operation.

Description

Units shall be factory-assembled, single packaged, air conditioners with electric cooling and electric heating units, designed for outdoor installation. They shall have built-in, equal size, field convertible duct connections for downflow supply and return or horizontal supply and return. The units shall be factory wired, piped, charged with R-410A refrigerant, and factory tested before shipment. All models shall be rated in accordance with DOE and AHRI test procedures for both heating and cooling operation. Units shall be CSA listed to the UL 1995/ CAN/CSA No. 236-M90 standards.

- **Operating efficiency** - All models shall be rated at a minimum of 14.0 SEER (13.4 SEER2) for cooling and heating operation rated in accordance with DOE requirements.
- **Low operating sound level** - The upward airflow carries the normal operating noise up and away from the living area. The rigid top panel effectively isolates noise. Isolator mounted compressor and the rippled fins of the outdoor coil muffle the normal fan motor and compressor operating sounds. The unique formed base pan also aids in sound attenuation with its structural design. Sound ratings as tested under AHRI test procedures shall be less than 77 dBA for all models.

Unit cabinet

Unit cabinet shall be a single-piece design, with drip edges and no-seam corners to provide optimum water integrity. Unit shall have a rigidly mounted outdoor coil guard to provide protection from objects and personnel after installation. Indoor blower section shall be insulated with foil-faced or foam insulation, fastened to prevent insulation from entering the air stream. Cabinet panels shall be separate and easily removable for servicing and maintenance. Unit shall be built on a formed, design base pan, with embossments at critical points to add strength and rigidity and aid in minimizing sound. Full perimeter base rails shall be provided to ensure reliable transit of equipment and facilitate overhead rigging, allowing truck access and sufficient sealing on roof curb applications. Base rails shall be easily removable if their removal is required to lower the unit height. Filters shall be field installed, furnished, and accessible through a removable access door, sealed airtight. The unit's vertical discharge and return duct configuration shall be designed to fit between standard 24 in. O.C. beams without modification to building structure, duct work, and base unit.

- **Durable finish** - The cabinet shall be made of G90 galvanized steel with a powder paint coating for appearance and protection. The pre-treated galvanized steel shall provide a better paint-to-steel bond, which resists corrosion and rust creep. Powder paint finish shall provide superior corrosion resistance and is 1,000 h salt spray tested.

- **On-site flexibility** - All model sizes shall use a compact design cabinet in one of two footprints. This provides installer flexibility for placing the correct capacity unit on curbs or pads with the smallest footprint after the internal load has been determined. Field convertible duct connections from side shot to down shot allow the installer to have greater flexibility with less inventory.
- **Attractive appearance** - A single-piece top cover containing a top-discharge outdoor fan arrangement shall be used. This requires less square footage on installation and provides a wider variety of installations. The one-piece design adds greater water integrity. Rounded corners with water drip edges add to the attractive appearance and prevent water penetration.
- **Convertible airflow design** - The bottom duct openings are covered when they leave the factory, ready to be used for a side supply and side return application. If a bottom supply and bottom return application is required, remove the two panels from the bottom of the unit and place them in the side supply and side return duct openings. No panel cutting is required and no accessory panel is necessary. The convertible airflow design allows maximum field flexibility and minimum inventory.
- **Utility connections made easy** - Electric utility access shall be provided through the bottom or the side of the unit. Utility connections must be made quickly and with a minimum amount of field labor. A field supplied and field installed electrical disconnect switch must be installed.
- **Easy service access** - Individual access panels provide access to all major components, for example, compressors, indoor coils, blowers, controls and electric heat kits, and filters, making servicing easy. Removing these panels allows easy removal of components such as the blower assembly for maintenance and troubleshooting.
- **Top discharge** - The top-discharge outdoor fan does not disrupt neighboring areas or dry out vegetation surrounding the unit. The warm air from the top mounted fan is blown up and away from the structure and any landscaping.
- **Outdoor coil grille** - All models use a stamped slotted design that provides superior impact protection against small objects during transit and after installation.
- **Indoor blower assembly** - Blower shall be direct drive design. Blower wheel shall be double-inlet type with forward-curved blades, dynamically balanced to operate smoothly throughout the entire range of operation. Airflow design shall be constant air volume. Bearings shall be sealed and permanently lubricated for longer life and no maintenance. Blower assembly shall be a slide-out design for easy removal and cleaning. Indoor blower motors shall be equipped with a standard high efficiency brushless DC motor (constant torque), also known as a standard ECM motor.
- **Outdoor fan assembly** - The outdoor fan shall be of the direct-driven propeller type, discharge air vertically, have aluminum blades riveted to corrosion resistant steel spider bracket, and be statically balanced for smooth operation. The outdoor fan motor shall be totally enclosed with permanently lubricated bearings and internally protected against overload conditions.

Refrigerant components

- **Protected compressor** - The compressor shall be a fully hermetic type, direct drive compressor, that is internally protected against high pressure and temperature. This is accomplished by the simultaneous operation of a high-pressure relief valve and a temperature sensor, which protects the compressor if undesirable operating conditions occur. The hermetic motor shall be suction gas cooled and have a voltage range of $\pm 10\%$ of the unit nameplate voltage. Compressors shall have internal isolation and sound muffling to minimize vibration and noise, and be externally isolated on a dedicated, independent mounting.
- **Indoor coils** - Indoor coils shall be of the direct expansion, draw through design and have aluminum plate fins mechanically bonded to seamless internally enhanced aluminum tubes with all joints brazed.
- **Condensate pan** - A corrosion-resistant, long-lasting, water-tight pan is positioned below the indoor coil to collect and drain all condensate, preventing build-up of stagnant condensate. The condensate pan conforms to ASHRAE 62-19 standards (Ventilation for Acceptable Indoor Air Quality).
- **Condensate drain** - The 3/4 in. NPT female connection is rigidly mounted to ensure correct fit and leak tight seal.
- **Outdoor coils** - Outdoor coils shall have aluminum plate fins mechanically bonded to seamless internally enhanced copper tubes with all joints brazed, and be a draw through design.

Refrigerant circuit and refrigerant safety components shall include the following:

- Thermal expansion valve (TXV) that is factory mounted and provided
- Filter or strainer to eliminate any foreign matter
- Reversing valves to control refrigerant flow

Controls

- **Simple control circuit** - Field thermostat wiring connects to color-coded leads using twist-on wire connections. Cooling controls use contactor and relays for simple application and troubleshooting. MATE-N-LOK plug connectors are used. The electrical control box is not located in the compressor compartment. The controls are mounted to allow the separate access panel to be removed for troubleshooting and maintenance without affecting the normal system operating pressures. All wiring internal to the unit is color-coded and numbered.
- **Pressure switches** - A high-pressure switch is standard in all units. It is an automatic reset switch. When discharge pressure reaches 650 psi, the compressor de-energizes until pressure reaches 450 psi.
- **Factory testing** - Installation time and costs are reduced by easy power and control wiring connections. All units are completely wired, charged with R-410A, and tested before shipment. Test stations using a state-of-the-art computerized process system shall be used to ensure product quality. Refrigerant charge and component part numbers are verified using computer bar code scans during assembly. Vital run test statistics such as system pressure, motor currents, air velocity and temperature, unit vibration, and gas system safeties are monitored and recorded by the system to ensure unit performance. This data could be provided by serial number tracking if requested.
- **Electric heat** - All electric heat models use 6HK electric heat, which is available in 208/230-3-60 from 10 kW to 25 kW. Most kits are stageable above 15 kW.

Physical data

Models		PCE4A36	PCE4B48	PCE4B60
Nominal tonnage		3.0	4.0	5.0
AHRI cooling performance	Gross capacity at AHRI A point (MBH)	35.9	48.1	58.3
	AHRI net capacity (MBH)	34.8	46.5	56.0
	EER	11.8	11.2	11.2
	EER2	11.0	11.0	11.0
	SEER	14.0	14.0	14.0
	SEER2	13.4	13.4	13.4
	Nominal CFM	1150	1550	1800
	System power (kW)	3.2	4.2	5.1
	Refrigerant type	R-410A	R-410A	R-410A
Refrigerant charge (lb-oz)	7-0	7-14	10-2	
Dimensions (in.)	Length	51 1/4	51 1/4	51 1/4
	Width	35 3/4	45 3/4	45 3/4
	Height	47	47	50
Operating weight (lb)		350	431	450
Compressor type		Scroll	Scroll	Scroll
Outdoor coil data	Face area (sq ft)	15.3	17.5	21.1
	Rows	2	2	2
	Fins per inch	22	22	22
	Tube diameter (mm)	7	7	7
	Circuitry type	Interlaced	Interlaced	Interlaced
Indoor coil data	Face area (sq ft)	4.6	6.2	6.2
	Rows	3	3	4
	Fins per inch	16	16	16
	Tube diameter (in.)	3/8	3/8	3/8
	Circuitry type	Interlaced	Interlaced	Interlaced
	Refrigerant control	TXV	TXV	TXV
Outdoor fan data	Fan diameter (in.)	24	26	26
	Type	Prop	Prop	Prop
	Drive type	Direct	Direct	Direct
	Number of speeds	1	1	1
	Motor (hp)	1/3	1/3	1/3
	RPM	850	850	850
	Nominal total CFM	2400	3200	3200
Direct drive indoor blower data	Blower size (in.)	11 x 10	11 x 10	11 x 10
	Type	Centrifugal	Centrifugal	Centrifugal
	Motor (hp)	1/2	3/4	1
	RPM	1400 Maximum	1400 Maximum	1400 Maximum
	Frame size	48	48	48
Filter size		A	B	B

Note: Field-supplied external filters must be sized so as not to exceed 300 fpm air velocity through disposable filters. All three-phase models include an internal filter rack kit and washable filters. Refer to the instructions supplied with the kit for replacement filter sizes. Filter sizes: A = 20 in. x 20 in., B = 20 in. x 30 in.

Cooling performance data - 5 ton																
Packaged unit model no. PCE4B6034																
Condenser entering air temp DB/WB (°F)	ID CFM	1600					1800					2000				
		80	80	75	80	80	80	80	75	80	80	80	80	75	80	80
IDDB (°F)	IDWB (°F)	57	62	62	67	72	57	62	62	67	72	57	62	62	67	72
55 / 45	Total capacity (MBH)	62.7	67.2	67.1	74.1	78.7	65.2	69.1	69.1	75.8	80.0	67.7	71.0	71.2	77.6	81.3
	Sensible capacity (MBH)	62.5	55.1	46.6	46.6	36.2	65.0	58.7	49.4	49.0	37.4	67.6	62.3	52.3	51.5	38.6
	Total power (kW)	3.16	3.17	3.17	3.18	3.20	3.23	3.24	3.24	3.25	3.27	3.30	3.31	3.32	3.33	3.35
65 / 55	Total capacity (MBH)	59.6	63.1	63.0	70.0	75.9	61.9	64.8	64.8	71.7	77.6	64.1	66.5	66.6	73.4	79.3
	Sensible capacity (MBH)	59.4	52.9	44.4	44.6	35.0	61.7	56.4	47.1	47.1	36.4	64.0	59.8	49.9	49.6	37.8
	Total power (kW)	3.47	3.49	3.49	3.51	3.53	3.55	3.56	3.56	3.58	3.61	3.63	3.64	3.64	3.66	3.69
75 / 63	Total capacity (MBH)	56.5	59.0	58.9	65.8	73.2	58.5	60.5	60.5	67.6	75.2	60.5	62.0	62.1	69.3	77.2
	Sensible capacity (MBH)	56.3	50.8	42.3	42.7	33.7	58.3	54.1	44.8	45.2	35.3	60.4	57.3	47.4	47.8	36.9
	Total power (kW)	3.79	3.81	3.80	3.84	3.87	3.87	3.88	3.88	3.91	3.95	3.95	3.96	3.96	3.99	4.03
85 / 69	Total capacity (MBH)	53.2	55.2	55.3	61.9	68.8	55.0	56.5	56.6	63.3	70.4	56.8	57.7	57.9	64.8	72.1
	Sensible capacity (MBH)	53.1	48.9	40.6	41.9	32.0	54.9	52.0	43.1	43.9	33.5	56.7	55.0	45.7	45.9	35.0
	Total power (kW)	4.16	4.18	4.18	4.22	4.25	4.25	4.26	4.25	4.29	4.33	4.33	4.34	4.33	4.37	4.41
95 / 75	Total capacity (MBH)	50.0	51.5	51.6	58.0	64.4	51.6	52.4	52.7	59.1	65.7	53.1	53.4	53.7	60.2	66.9
	Sensible capacity (MBH)	49.9	47.1	39.0	41.1	30.3	51.4	49.9	41.5	42.5	31.6	53.0	52.7	43.9	44.0	33.0
	Total power (kW)	4.54	4.55	4.55	4.59	4.63	4.63	4.63	4.63	4.67	4.71	4.71	4.71	4.70	4.74	4.79
105 / 83	Total capacity (MBH)	46.5	48.3	47.2	54.0	59.7	48.0	49.4	48.2	54.5	60.9	49.5	50.4	49.2	55.0	62.1
	Sensible capacity (MBH)	46.4	45.2	36.7	38.5	28.2	47.9	47.4	39.0	40.0	29.5	49.4	49.7	41.4	41.5	30.8
	Total power (kW)	5.04	5.05	5.02	5.09	5.12	5.13	5.13	5.10	5.16	5.20	5.21	5.21	5.18	5.23	5.28
115 / 89	Total capacity (MBH)	43.1	45.3	43.0	50.1	55.1	44.6	46.4	43.9	50.1	56.2	46.1	47.5	44.8	50.0	57.3
	Sensible capacity (MBH)	43.0	43.3	34.4	36.0	26.2	44.5	45.0	36.6	37.6	27.4	45.9	46.7	38.9	39.1	28.6
	Total power (kW)	5.52	5.53	5.48	5.57	5.58	5.61	5.62	5.56	5.64	5.67	5.70	5.70	5.65	5.71	5.76
125 / 95	Total capacity (MBH)	39.8	42.2	38.8	46.2	50.5	41.2	43.4	39.6	45.6	51.6	42.6	44.7	40.4	45.0	52.6
	Sensible capacity (MBH)	39.7	41.5	32.2	33.5	24.1	41.1	42.6	34.3	35.1	25.3	42.5	43.8	36.3	36.8	26.5
	Total power (kW)	6.00	6.02	5.94	6.06	6.05	6.10	6.10	6.03	6.12	6.14	6.19	6.18	6.11	6.18	6.23

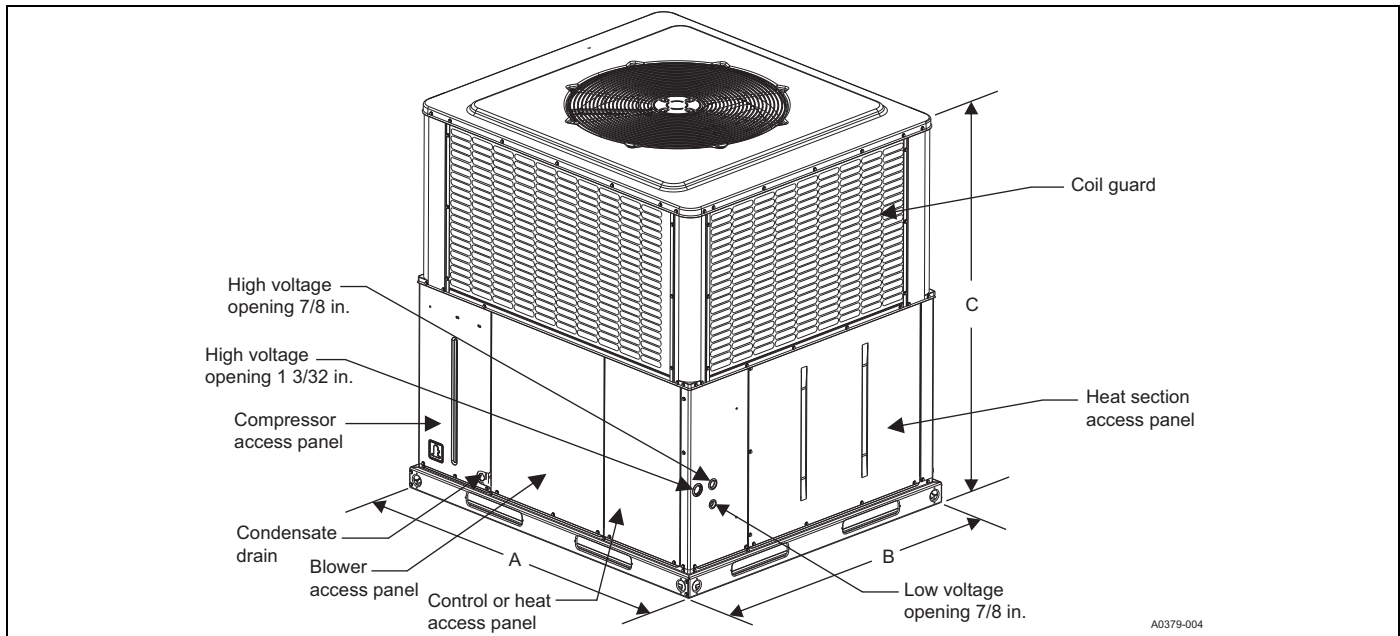

Unit dimensions and access locations

Model	Dimensions (in.)		
	A	B	C
PCE4A3634	51 1/4	35 3/4	47
PCE4B4834	51 1/4	45 3/4	47
PCE4B6034	51 1/4	45 3/4	50

Unit clearances

Direction	Distance (in.)	Direction	Distance (in.)
Top ¹	36	Right side	36
Side opposite ducts	36	Left side	24
Duct panel	0	Bottom ^{2,3}	1

1. Provide a minimum clearance of 1 in. on all sides of the supply air duct for the first 3 ft of the duct for 20 kW and 25 kW heaters (0 in. thereafter). For all other heaters, make sure that there is 0 in. clearance on all sides for the entire length of the supply air duct.

2. Install units outdoors. Make sure that overhanging structures or shrubs do not obstruct the outdoor air discharge outlet.

3. You can install units on combustible materials made from wood or class A, B, or C roof covering materials if factory base rails are left in place as shipped.

Note: For units installed on a roof curb, you can reduce the minimum clearance between combustible roof curb material and the supply air duct from 1 in. to 1/2 in.

Electric heat minimum supply air

Model	Voltage-phase-frequency	Minimum blower speed for electric heat			
		Heater kW			
		10	15	20	25
PCE4A3634	208/230-3-60	Medium low (2)	Medium high (4)	—	—
PCE4B4834	208/230-3-60	Medium (3)	Medium (3)	Medium high (4)	—
PCE4B6034	208/230-3-60	Medium (3)	Medium (3)	Medium high (4)	Medium high (4)

Indoor blower specifications

Model	Motor				
	hp	RPM	Efficiency	SF	Frame
PCE4A3634	1/2	Variable	0.8	1.0	48
PCE4B4834	3/4	Variable	0.8	1.0	48
PCE4B6034	1	Variable	0.8	1.0	48

Sound performance

Model	Sound rating ¹ dBA	Octave band centerline frequency (Hz)						
		125	250	500	1000	2000	4000	8000
PCE4A3634	76	78.7	71.9	73.8	72.5	66.1	61.2	55.0
PCE4B4834	72	76.2	69.4	67.8	69.0	63.0	61.0	55.0
PCE4B6034	73	76.6	70.4	68.2	69.0	64.0	62.4	56.7

1. Rated in accordance with AHRI Standard 270.

Single point kit numbers

Unit model number	Voltage	Heater kit	Single-point wiring kit	Unit fuse size (A)	Heater fuse size (A)
PCE4A36	208-3-60	6HK06501025	S1-2SPWK031	20	25
		6HK06501525	S1-2SPWK033	20	40
PCE4B48		6HK06501025	S1-2SPWK031	30	25
		6HK06501525	S1-2SPWK033	30	40
PCE4B60		6HK16502025	S1-2SPWK038	30	n/a*
		6HK06501025	S1-2SPWK032	35	25
		6HK06501525	S1-2SPWK034	35	40
		6HK16502025	S1-2SPWK035	35	n/a*
		6HK16502525	S1-2SPWK035	35	n/a*
PCE4A36		230-3-60	6HK06501025	S1-2SPWK031	20
	6HK06501525		S1-2SPWK033	20	45
PCE4B48	6HK06501025		S1-2SPWK031	30	30
	6HK06501525		S1-2SPWK033	30	45
PCE4B60	6HK16502025		S1-2SPWK038	30	n/a*
	6HK06501025		S1-2SPWK032	35	30
	6HK06501525		S1-2SPWK034	35	45
	6HK16502025		S1-2SPWK035	35	n/a*
	6HK16502525		S1-2SPWK035	35	n/a*

* The 208/230 V 20 kW and 25 kW heater kits include circuit breakers, so no fuse is needed.

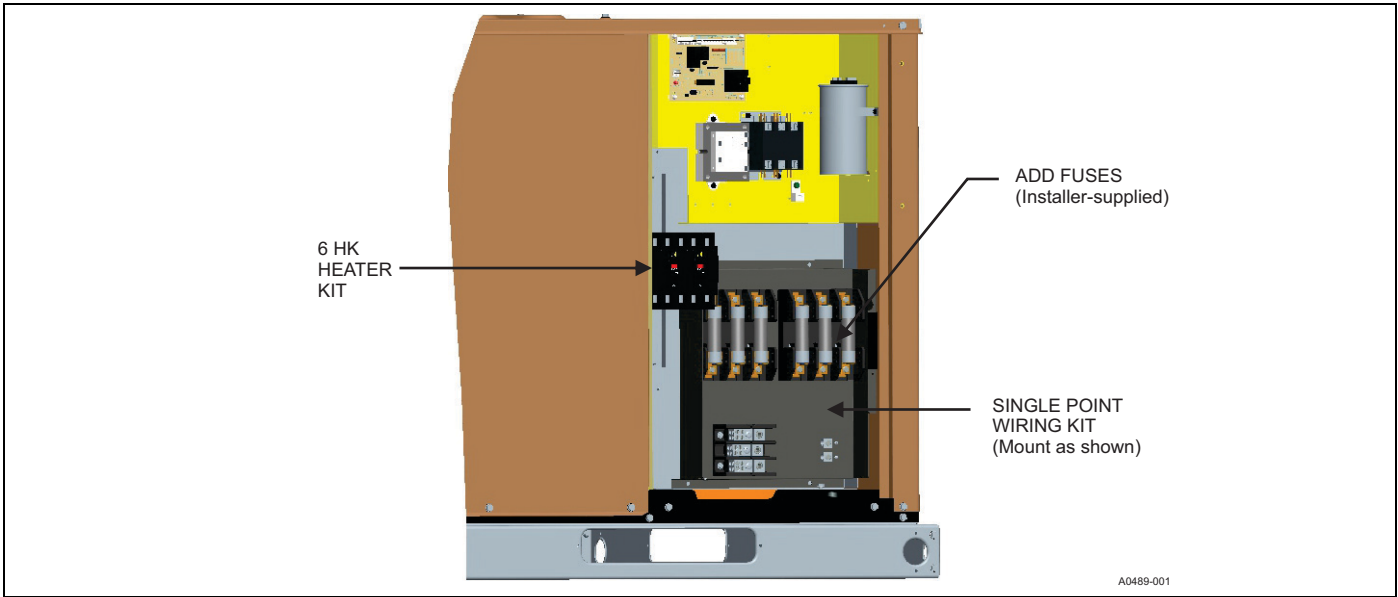

Electrical data - 208/230-3-60 single source power

Model	Compressor			OD fan motor	Blower motor	Electric heat option					MCA ¹		Max fuse ² or breaker ³ size		MCA ¹		Max fuse ² or breaker size ³		
						Heater kit ⁴		Heater (kW)		Stages	Heater (A)		Total unit		Total unit		Unit less heater		Unit less heater
	RLA	LRA	MCC	FLA	FLA	208	230	208	230		208	230	208	230	208	230	208	230	
PCE4A36	8.5	70.0	13.2	1.7	3.8	none	—	—	—	—	—	16.1	16.1	20	20	16.1	16.1	20	20
						6HK06501025	7.2	8.8	1	20.0	22.1	29.8	32.4	30	35	16.1	16.1	20	20
						6HK06501525	10.8	13.2	1	30.0	33.2	42.3	46.2	45	50	16.1	16.1	20	20
PCE4B48	10.4	123.0	16.3	1.7	5.4	none	—	—	—	—	—	20.2	20.2	30	30	20.2	20.2	30	30
						6HK06501025	7.2	8.8	1	20.0	22.1	31.8	34.4	35	35	20.2	20.2	30	30
						6HK06501525	10.8	13.2	1	30.0	33.2	44.3	48.2	45	50	20.2	20.2	30	30
PCE4B60	13.2	93.0	20.6	1.7	7.0	6HK16502025	14.4	17.6	2	40.0	44.3	56.8	62.1	60	70	20.2	20.2	30	30
						none	—	—	—	—	—	25.2	25.2	35	35	25.2	25.2	35	35
						6HK06501025	7.2	8.8	1	20.0	22.1	33.8	36.4	35	40	25.2	25.2	35	35
						6HK06501525	10.8	13.2	1	30.0	33.2	46.3	50.2	50	60	25.2	25.2	35	35
						6HK16502525	14.4	17.6	2	40.0	44.3	58.8	64.1	60	70	25.2	25.2	35	35
						6HK16502525	18.0	22.0	2	50.0	55.3	71.3	77.9	80	80	25.2	25.2	35	35

- 1. Minimum circuit ampacity.
- 2. Maximum overcurrent protection per standard UL 1995.
- 3. Fuse or HACR circuit breaker is field installed.
- 4. Single-point connection kit is required.

Notes: Single source power MCA and MOP requirements are given here for reference if the unit is installed with a field installed single-point power modification.

Electrical data - 208-3-60 multi source power

Model	Compressor			OD Fan Motor	Blower Motor	Electric heat option				Multi source (208 V)					
										Circuit 1 (compressor)		Circuit 2 (heat)		Circuit 3 (heat)	
	RLA	LRA	MCC	FLA	FLA	Heat kit	Heater (kW)	Stages	Heater (A)	MCA ¹ (A)	MOP ²	MCA ¹ (A)	MOP ²	MCA ¹ (A)	MOP ²
PCE4A36	8.5	70.0	13.2	1.7	3.8	none	—	—	—	16.1	20	—	—	—	—
						6HK06501025	7.2	1	20.0	16.1	20	25.0	25	—	—
						6HK06501525	10.8	1	30.0	16.1	20	37.5	40	—	—
PCE4B48	10.4	123.0	16.3	1.7	5.4	none	—	—	—	20.2	30	—	—	—	—
						6HK06501025	7.2	1	20.0	20.2	30	25.0	25	—	—
						6HK06501525	10.8	1	30.0	20.2	30	37.5	40	—	—
						6HK16502025	14.4	2	40.0	20.2	30	25.0	25	25.0	25
PCE4B60	13.2	93.0	20.6	1.7	7.0	none	—	—	—	25.2	35	—	—	—	—
						6HK06501025	7.2	1	20.0	25.2	35	25.0	25	—	—
						6HK06501525	10.8	1	30.0	25.2	35	37.5	40	—	—
						6HK16502025	14.4	2	40.0	25.2	35	25.0	25	25.0	25
						6HK16502525	18.0	2	50.0	25.2	35	31.3	35	31.3	35

1. MCA = minimum circuit ampacity.

2. MOP = maximum overcurrent protection device. Must be HACR type circuit breaker or time delay fuse.

Electrical data - 230-3-60 multi source power

Model	Compressor			OD Fan Motor	Blower Motor	Electric heat option				Multi source (230 V)					
										Circuit 1 (compressor)		Circuit 2 (heat)		Circuit 3 (heat)	
	RLA	LRA	MCC	FLA	FLA	Heat kit	Heater (kW)	Stages	Heater (A)	MCA ¹ (A)	MOP ²	MCA ¹ (A)	MOP ²	MCA ¹ (A)	MOP ²
PCE4A36	8.5	70.0	13.2	1.7	3.8	none	—	—	—	16.1	20	—	—	—	—
						6HK06501025	8.8	1	22.1	16.1	20	27.7	30	—	—
						6HK06501525	13.2	1	33.2	16.1	20	41.5	45	—	—
PCE4B48	10.4	123.0	16.3	1.7	5.4	none	—	—	—	20.2	30	—	—	—	—
						6HK06501025	8.8	1	22.1	20.2	30	27.7	30	—	—
						6HK06501525	13.2	1	33.2	20.2	30	41.5	45	—	—
						6HK16502025	17.6	2	44.3	20.2	30	27.7	30	27.7	30
PCE4B60	13.2	93.0	20.6	1.7	7.0	none	—	—	—	25.2	35	—	—	—	—
						6HK06501025	8.8	1	22.1	25.2	35	27.7	30	—	—
						6HK06501525	13.2	1	33.2	25.2	35	41.5	45	—	—
						6HK16502025	17.6	2	44.3	25.2	35	27.7	30	27.7	30
						6HK16502525	22.0	2	55.3	25.2	35	34.6	35	34.6	35

1. MCA = minimum circuit ampacity.

2. MOP = maximum overcurrent protection device. Must be HACR type circuit breaker or time delay fuse.

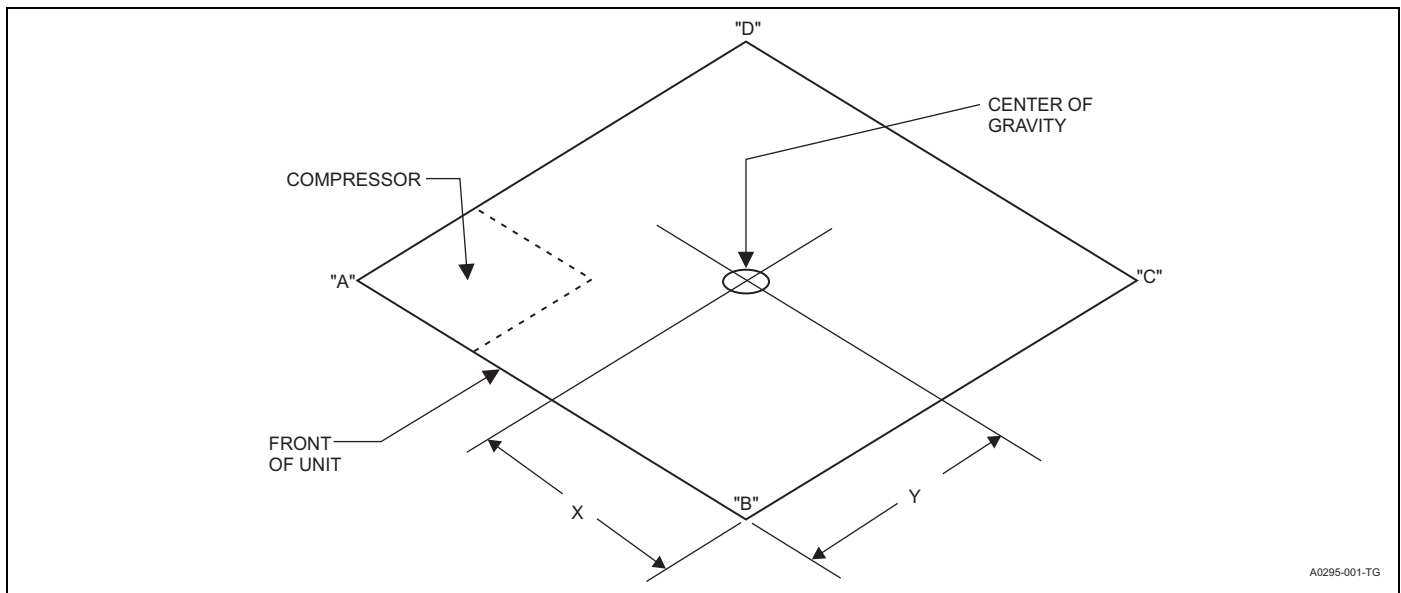

A0295-001-TG

Weights and dimensions

Model	Weight (lb)		Center of gravity (in.)		Four-point load location (lb)			
	Shipping	Operating	X	Y	A	B	C	D
PCE4A3634	355	350	30	15	130	72	75	73
PCE4B4834	436	431	30	19	165	88	94	84
PCE4B6034	455	450	29	18	177	94	97	82

Airflow performance - side duct application

Model	Motor speed	External static pressure (in. W.C.)								
		0.1 SCFM	0.2 SCFM	0.3 SCFM	0.4 SCFM	0.5 SCFM	0.6 SCFM	0.7 SCFM	0.8 SCFM	1.0 SCFM
PCE4A36	Low (1)	850	790	710	660	610	560	510	450	400
	Medium low (2)	1150	1110	1070	1020	970	910	860	820	730
	Medium (3)	1270	1230	1190	1150	1110	1060	1000	960	860
	Medium high (4)	1370	1340	1300	1260	1220	1180	1130	1070	980
	High (5)	1490	1450	1420	1380	1340	1300	1260	1210	1120
PCE4B48	Low (1)	1140	1090	1030	980	920	850	780	730	600
	Medium low (2)	1350	1300	1250	1200	1160	1100	1050	1000	870
	Medium (3)	1690	1650	1600	1570	1530	1490	1440	1400	1310
	Medium high (4)	1800	1760	1720	1680	1650	1610	1560	1520	1440
	High (5)	2020	1980	1940	1910	1870	1830	1790	1760	1690
PCE4B60	Low (1)	1300	1240	1200	1150	1090	1050	1000	940	820
	Medium low (2)	1610	1570	1540	1500	1450	1420	1380	1340	1260
	Medium (3)	1870	1840	1810	1770	1730	1690	1650	1620	1540
	Medium high (4)	2000	1970	1930	1890	1860	1830	1780	1740	1670
	High (5)	2240	2210	2180	2150	2100	2070	2040	2010	1940

Notes:

Airflow is tested with dry coil conditions, without air filters, at 230 V.
 Applications above 0.8 in. W.C. external static pressure are not recommended.
 Brushless DC high-efficiency standard ECM blower motor is used for all indoor blower assemblies.
 Minimal variations in airflow performance data result from operating at 208 V. The data in the table can be used in those cases.
 Heating applications are tested at 0.5 in. W.C. external static pressure. Cooling applications are tested per AHRI Standard 210/240.
 The differences between side duct airflows and bottom duct airflows are insignificant.

Electric heat performance data

Heater models ¹	Nominal kW at 240 V	Total heat				kW staging			
		kW		MBH		W1 Only		W1 + W2	
		208 V	230 V	208 V	230 V	208 V	230 V	208 V	230 V
6HK06501025	9.6	7.2	8.8	24.6	30.1	7.2	8.8	7.2	8.8
6HK06501525	14.4	10.8	13.2	36.9	45.1	10.8	13.2	10.8	13.2
6HK16502025	19.2	14.4	17.6	49.2	60.2	7.2	8.8	14.4	17.6
6HK16502525	24.0	18.0	22.0	61.5	75.2	9.0	11.0	18.0	22.0

1. 6HK0 = no service disconnect. 6HK1 = with service disconnect

Additional static resistance

Size (ton)	CFM	Wet indoor coil	Economizer ¹	Filter/frame kit
36 (3.0)	700	0.01	0.00	0.04
	800	0.02	0.01	0.06
	900	0.03	0.01	0.08
	1000	0.04	0.01	0.10
	1100	0.05	0.01	0.13
	1200	0.06	0.02	0.16
	1300	0.07	0.03	0.17
48 (4.0)	1100	0.02	0.02	0.04
	1200	0.03	0.02	0.04
	1300	0.04	0.02	0.05
	1400	0.05	0.03	0.05
	1500	0.06	0.04	0.06
	1600	0.07	0.04	0.07
	1700	0.07	0.04	0.08
	1800	0.08	0.04	0.09
	1900	0.09	0.05	0.10
60 (5.0)	1100	0.02	0.02	0.04
	1200	0.03	0.02	0.04
	1300	0.04	0.02	0.05
	1400	0.05	0.03	0.05
	1500	0.06	0.04	0.06
	1600	0.07	0.04	0.07
	1700	0.07	0.04	0.08
	1800	0.08	0.04	0.09
	1900	0.09	0.05	0.10
	2000	0.09	0.05	0.11

1. The pressure drop through the economizer is greater for 100% outdoor air than for 100% return air. If the resistance of the return air duct is less than 0.25 IWG, the unit delivers less CFM during full economizer operation.

Note: Filter pressure drop based on standard filter media tested at velocities not to exceed 300 ft/min.

Bottom duct dimensions (in.)

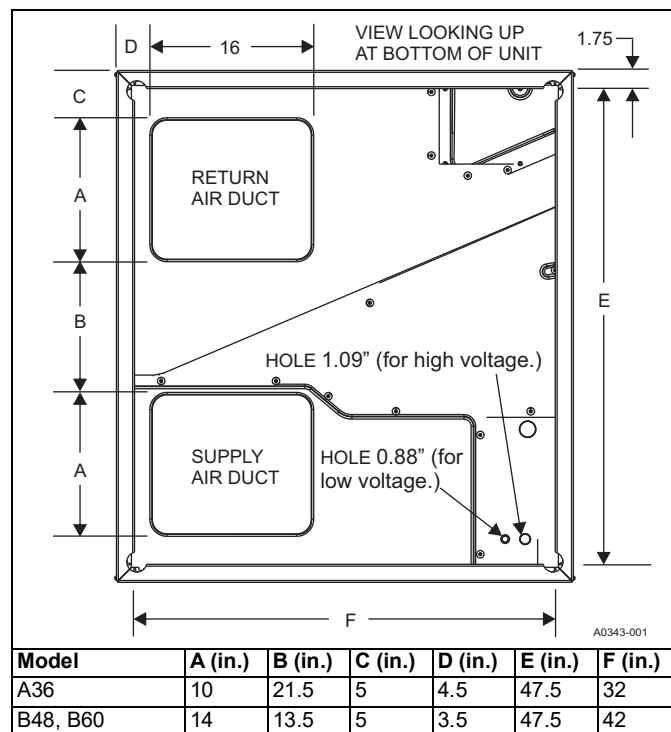

Rear duct dimensions (in.)

NOTE: See Figure titled "Unit Dimensions" for side hole sizes of electrical lines.

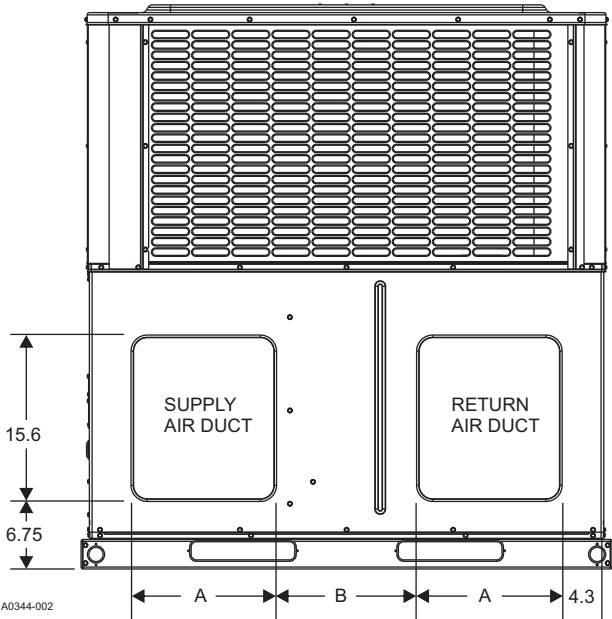

Model	A (in.)	B (in.)
A36	9.6	22
B48, B60	13.6	14

Unit typical duct applications

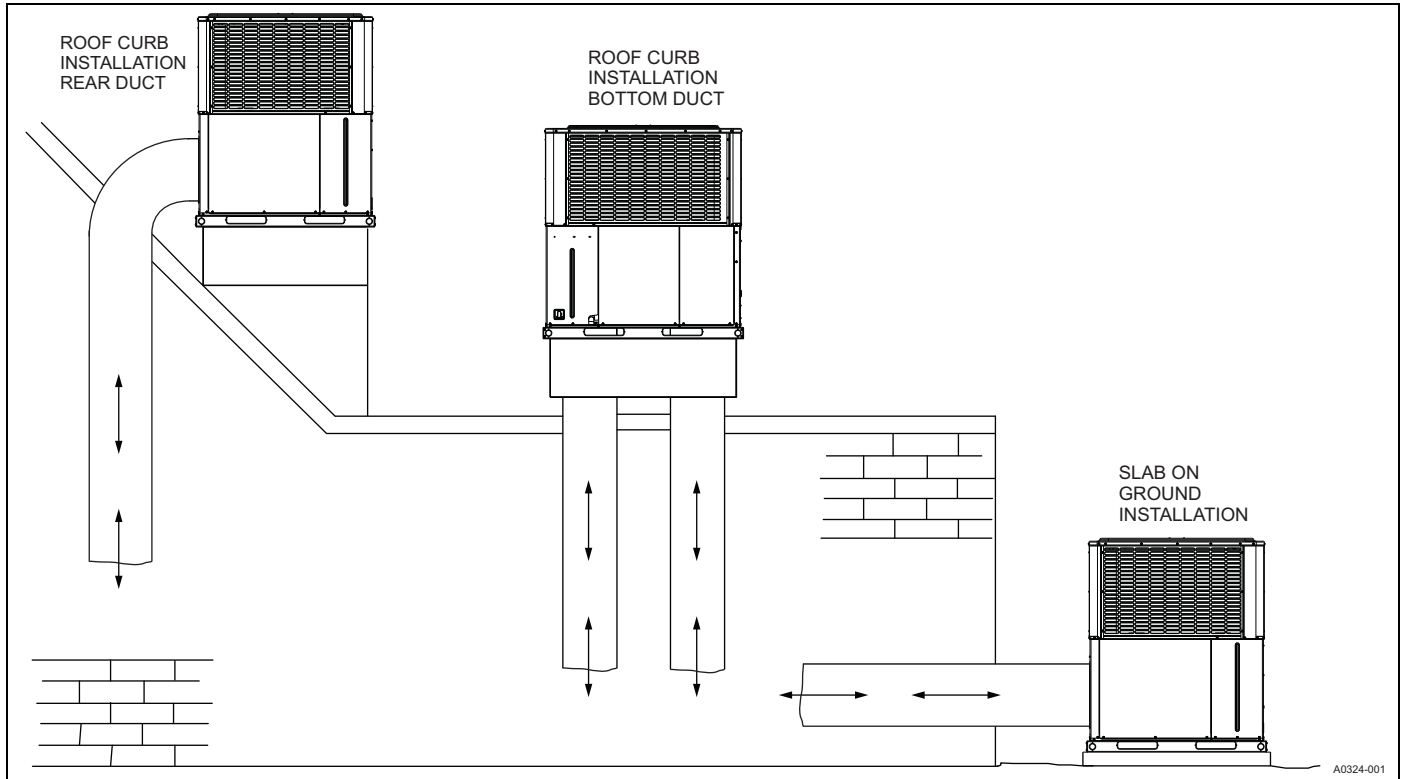

Unit typical slab on ground installation

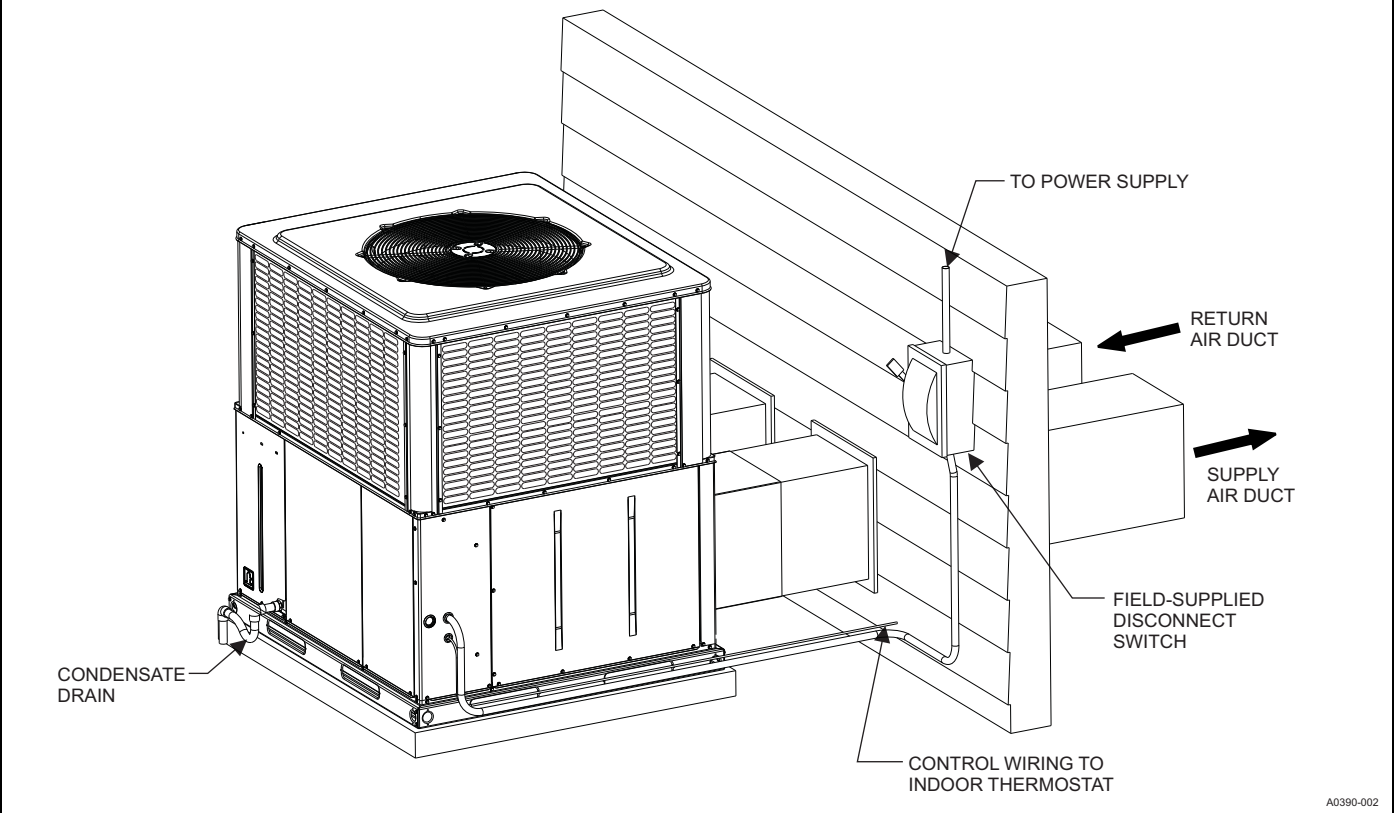

Unit typical roof curb installation

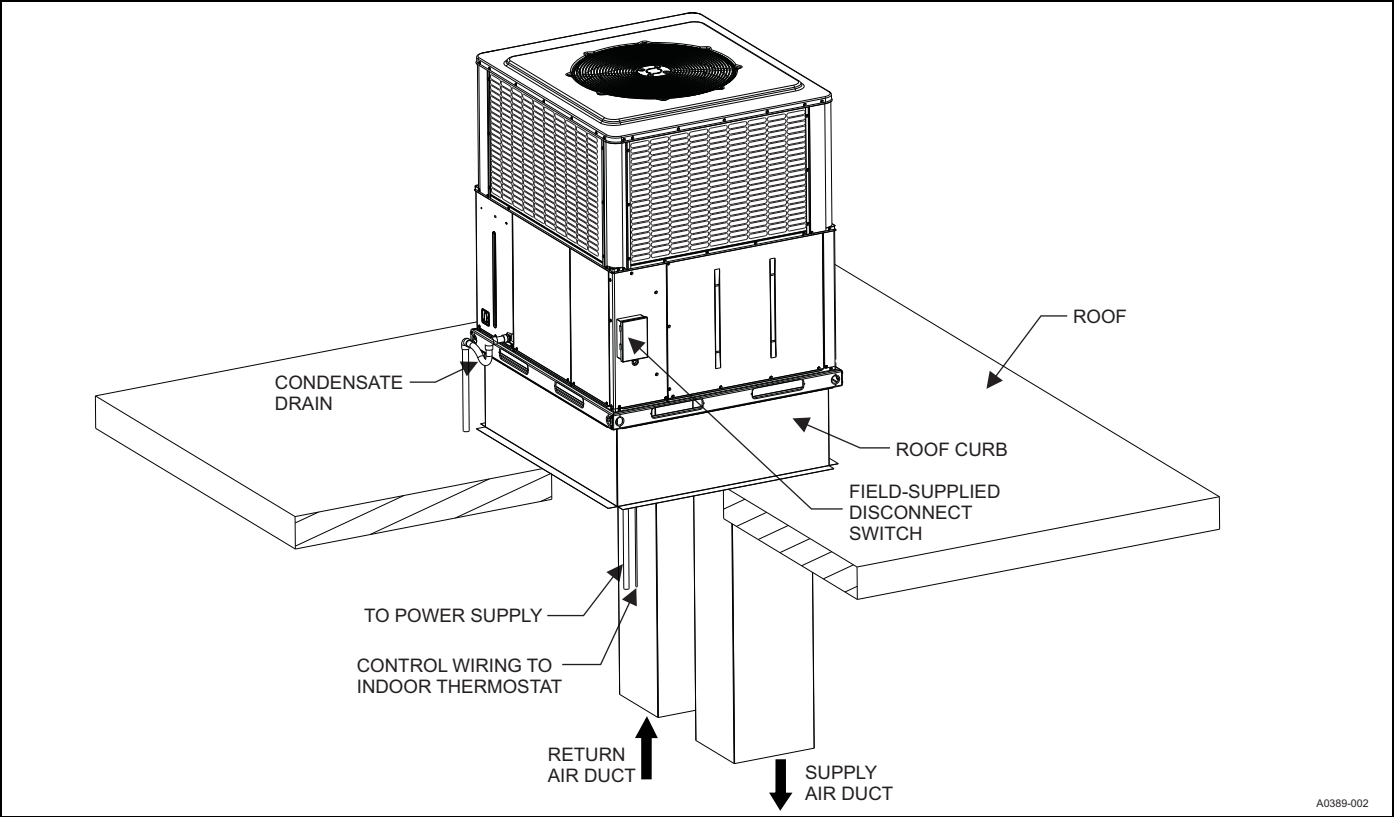

Third-Party Trademarks Notice: For information about third-party trademarks, refer to the relevant company websites.

Notes